

ecostore

2 Half Door Digital Stainless Steel Refrigerator, 670lt (0/+6) R290 - UK Plug

ITEM # _____

MODEL # _____

NAME # _____

SIS # _____

AIA # _____

725287 (RE472HRCG)

 2-half door Refrigerator
 670lt, 0+6°C, digital, stainless
 steel, R290 - UK plug

Short Form Specification

Item No. _____

Two half door refrigerator with internal and external structure in 430 AISI stainless steel; external back panel in galvanized steel and bottom panel in anti-corrosive material. Digital control with cabinet temperature display and setting and manual activation of defrost cycle. Fully compliant HACCP digital controls include visible alarms. Optimized back to front forced air flow provides even temperature distribution and fast cooling in any conditions. Fitted with 75 mm-thick cyclopentane insulating foam. On-site reversible door features lock and door microswitch to switch off the fan when the door is opened. Hidden evaporator to guarantee higher storage capacity and less corrosion problems. Built-in refrigeration unit; ventilated operation; automatic defrost and evaporation of defrost water. Operating temperature: 0/+6 °C. CFC and HCFC free. R290 gas in refrigeration circuit.

Integrated RS485 port to facilitate connection to a remote computer and integrated HACCP systems. Mounted on wheels and equipped with UK plug.

Main Features

- Right hinged two 1/2 doors.
- Large storage area suitable to contain 2/1 GN grids or shelves on anti-tilt runners.
- Optimized back to front forced air flow provide even temperature distribution and fast cooling in any conditions.
- Automatic defrost.
- Internal structure with numerous charging positions available to host grids, ensuring higher net capacity and a greater storage space.
- Operating temperatures can be adjusted from 0 to +6 °C to suit both meat and dairy storage requirements.
- Cabinet fitted with up to 75 mm thickness of cyclopentane insulation for best insulating performance with 100% environmental protection (thermal conductivity: 0,020 W/m*K).
- 60 mm-thick insulation covering the evaporator can be easily removed with a single operation.
- Rilsan coated grids for improved protection.
- Hidden evaporator thus guaranteeing higher storage capacity and less corrosion problems.
- Connectivity ready for real time access to connected appliances from remote and data monitoring (requires optional accessory).
- Right hinged full door.
- Integrated RS485 port to facilitate connection to a remote computer and integrated HACCP systems.
- Easy serviceability thanks to the intuitive control panel with access via app.
- Large digital white-digit display with cabinet temperature display and setting, activation of turbo frost cycle (to rapidly cool warm loads) and possibility to activate manually the defrost cycle.

Construction

- Stainless steel runners and supports easily disassembled.
- Anti-corrosion bottom avoids any damage that may be caused to the cabinet by aggressive detergents employed to clean the floors.
- Lockable door.
- Doors are self-closing and can be fully opened up to 180°.
- Mounted on wheels.
- The rounded internal corners, the easily removable runners and grids allow for ease of cleaning and high hygiene standards.
- Delivered with UK plug.
- AISI 430 stainless steel internal structure and external panels.
- Easy access to the main components for maintenance.

Sustainability

- Automatic evaporation of the defrosting water by hot gas on the top for energy saving.
- Door switch stops the fan when door is opened

APPROVAL: _____

to avoid cold air exiting the cell, thus saving energy.

- Removable triple-chamber balloon magnetic gasket to improve insulation and reduce energy consumption and ease of cleaning.
- CFC and HCFC free, highly ecological refrigerant type: R290 (ecological gas in foam: cyclopentane). Hydrocarbon refrigerant gas R290 for the lowest environmental impact (GWP=3), to reduce green house and ozone depletion effects.
- Cleaning-free condenser: the structure of the wire frame condenser prevents dust and grease accumulation thus avoiding periodical cleaning operations and reducing energy consumption.

Included Accessories

- 3 of 2/1GN grey rilsan grid with 2 runners PNC 881020
- 1 of Kit of 4 small swivelling wheels, 2 with brake, diam 50 mm, not for remote models PNC 881035

Optional Accessories

- 2 stainless steel runners for refrigerated cabinets - (Marine) PNC 880242
- Spacer for 670 lt and 1430 lt refrigerated cabinets PNC 880248
- 1/1GN plastic container with false bottom PNC 880705
- 4 swivelling wheels (2 with brake), diam 125 mm, for refrigerators, NOT for remote models PNC 881002
- 2/1GN grey rilsan grid PNC 881004
- 2/1GN aisi 304 stainless steel grid PNC 881016
- 2/1GN 304 AISI stainless steel grid with 2 runners PNC 881018
- Meat rail for 670/1430lt refrigerators with 4 hooks PNC 881019
- 2/1GN grey rilsan grid with 2 runners PNC 881020
- Set of 2 stainless steel runners for 670/1430lt refrigerators and freezers PNC 881021
- Kit of 4 small swivelling wheels, 2 with brake, diam 50 mm, not for remote models PNC 881035
- 2/1GN perforated shelf PNC 881042
- 1/1GN rilsan steel wire basket h=150mm PNC 881043

Front

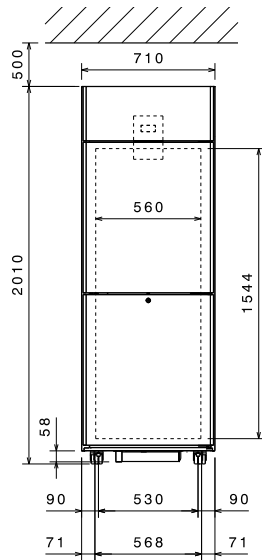

Side

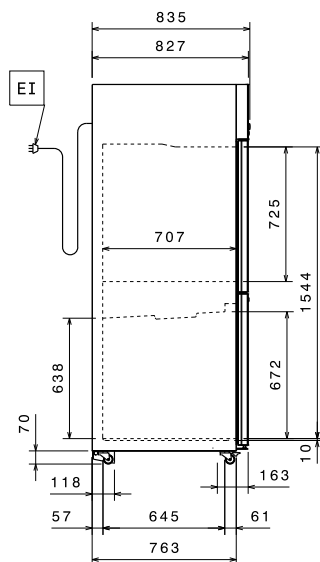

EI = Electrical inlet (power)

Top

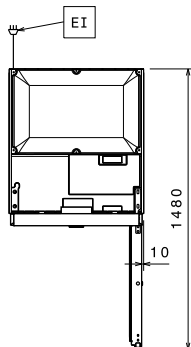
Electric

Supply voltage:	
725287 (RE472HRCG)	220-240 V/1 ph/50 Hz
Electrical power max.:	0.2 kW

Key Information:

Gross capacity:	670 lt
Net Volume:	497 lt
Door hinges:	2 Right
External dimensions, Width:	710 mm
External dimensions, Depth:	835 mm
External dimensions, Depth with Doors Open:	1480 mm
External dimensions, Height:	2010 mm
Number and type of doors:	2x1/2 Full
Number and type of grids (included):	3 - GN 2/1
Type of external material:	Stainless Steel
Type of internal material:	Stainless Steel
Internal panels material:	Stainless Steel
Number of positions & pitch:	40; 30 mm

Refrigeration Data

Control type:	Digital
Refrigeration power at evaporation temperature:	-10 °C
Operating temperature min.:	0 °C
Operating temperature max.:	6 °C
Operating mode:	Ventilated

Product Information (EU Regulation 2015/1094)

Type of model (EU Reg. 2015/1094):	vertical chilled
---	------------------

ISO Certificates

ISO Standards:	ISO 9001; ISO 14001; ISO 45001; ISO 50001
-----------------------	---

Sustainability

Energy Class (EU Reg. 2015/1094):	D
Yearly and daily energy consumption (EU Reg. 2015/1094):	760kWh/year - 2kWh/24h
Climate class (EU Reg. 2015/1094):	Heavy Duty (5)
Energy Efficiency Index-EEI (EU Reg. 2015/1094):	53,31
Refrigerant type:	R290
GWP Index:	3
Refrigeration power:	322 W
Refrigerant weight:	70 g

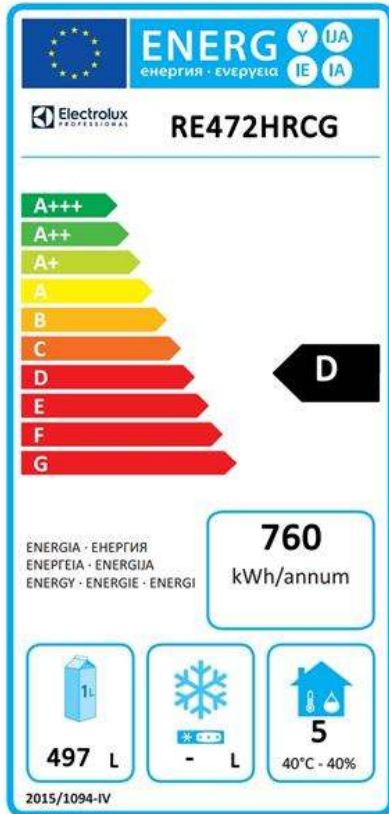

EU energy labelling from 1st July 2016

The European energy labelling scheme for professional refrigerators and freezers is based on requirements setting Minimum Energy Performance standards for commercial refrigeration cabinets sold within the EU.

These requirements are designed to drive energy efficiency and environmentally friendly approach for professionals. The European energy labelling scheme will apply to all manufacturers and importers who sell and market products within the EU and it is mandatory across Europe. Important: all products which consume energy above the minimum level will not be able to be sold within the EU from 1 July 2016.

SI 2020 No. 1528.

Important: all products which consume energy above the minimum level will not be able to be sold within the EU from 1 July 2016.

